

# Inverter

## MICROMASTER 430



- 3/2 Description
- 3/4 Circuit diagrams
- 3/6 Technical data
- 3/9 Selection and ordering data
- 3/10 Options
- 3/17 Dimension drawings

## Description



### Applications

The MICROMASTER 430 inverter is suitable for a variety of variable-speed drive applications. Its flexibility provides for a wide spectrum of applications. It is especially suitable for use with industrial pumps and fans. The inverter is especially characterized by its customer-oriented performance and ease-of-use. It has more inputs and outputs than the MICROMASTER 420, an optimized operator panel with manual/automatic switchover and adapted software functionality.

### Design

The MICROMASTER 430 inverter has a modular design. The operator panels and communication modules can be easily exchanged.

### Main characteristics

- Easy, guided start-up
- Modular construction allows maximum configuration flexibility
- Six programmable isolated digital inputs
- Two scaleable analog inputs (0 V to 10 V, 0 mA to 20 mA) can also be used as a 7th/8th digital input
- Two programmable analog outputs (0 mA to 20 mA)
- Three programmable relay outputs (30 V DC/5 A resistive load; 250 V AC/2A inductive load)
- Low-noise motor operation thanks to high pulse frequencies, adjustable (observe derating if necessary)
- Complete protection for motor and inverter
- Control of up to three additional drives on the basis of PID control (motor staging)
- Operation of drive directly on mains (with external bypass circuit)
- Low-energy mode
- Detects dry run of pumps (belt failure detection).

### Options (overview)

- Line commutating chokes
- Output chokes
- LC filter
- Gland plates
- Basic Operator Panel 2 (BOP-2) for parameterizing the inverter
- Communication modules
  - PROFIBUS
  - DeviceNet
  - CANopen
- PC connection kits
- Mounting kits for installing the operator panels in the control cabinet doors
- PC start-up tools executable under Windows 95/98 and NT/2000/XP Professional.
- TIA integration with Drive ES

### International standards

- The MICROMASTER 430 inverter complies with the requirements of the EU low-voltage guideline
- The MICROMASTER 430 inverter has the **CE** marking
- acc. to **UL** and **cUL** certified
- c-tick **CCC**

#### Note:

See Appendix for standards.

**Mechanical features**

- Modular design
- Operating temperature  
–10 °C to +40 °C  
(+14 °F to +104 °F)
- Compact housing as a result of high power density
- Easy cable connection, mains and motor connections are separated for optimum electromagnetic compatibility
- Detachable operator panels
- Screwless control terminal strip on detachable I/O board.

**Performance features**

- Latest IGBT technology
- Digital microprocessor control
- Flux Current Control (FCC) for improved dynamic response and optimized motor control
- Linear  $V/f$  characteristic
- Quadratic  $V/f$  characteristic
- Multipoint characteristic (programmable  $V/f$  characteristic)
- Flying restart
- Slip compensation
- Automatic restart following mains failure or fault
- Energy saving mode (stopping e.g. of a pump at low speeds)
- Motor staging (connection and disconnection of additional motors, use of inverter as control drive in a pump cascade)
- Manual/automatic mode
- Load torque monitoring (detects dry run of pumps)

**Protection features**

- Overload capability  
7.5 kW to 90 kW:  
Overload current 1.4 x rated output current (i.e. +140 % overload capability) for 3 s, and 1.1 x rated output current (i.e. 110 % overload capability) for 60 s, cycle time 300 s  
110 kW to 250 kW:  
Overload current 1.5 x rated output current (i.e. 150 % overload capability) for 1 s, and 1.1 x rated output current (i.e. 110 % overload capability) for 59 s, cycle time 300 s
- Overvoltage/undervoltage protection
- Inverter overtemperature protection
- Special direct connection for PTC or KTY to protect the motor
- Earth fault protection
- Short-circuit protection
- $I^2t$  motor thermal protection
- Locked motor protection
- Stall prevention
- Parameter interlock

## Circuit diagrams

### General circuit diagram

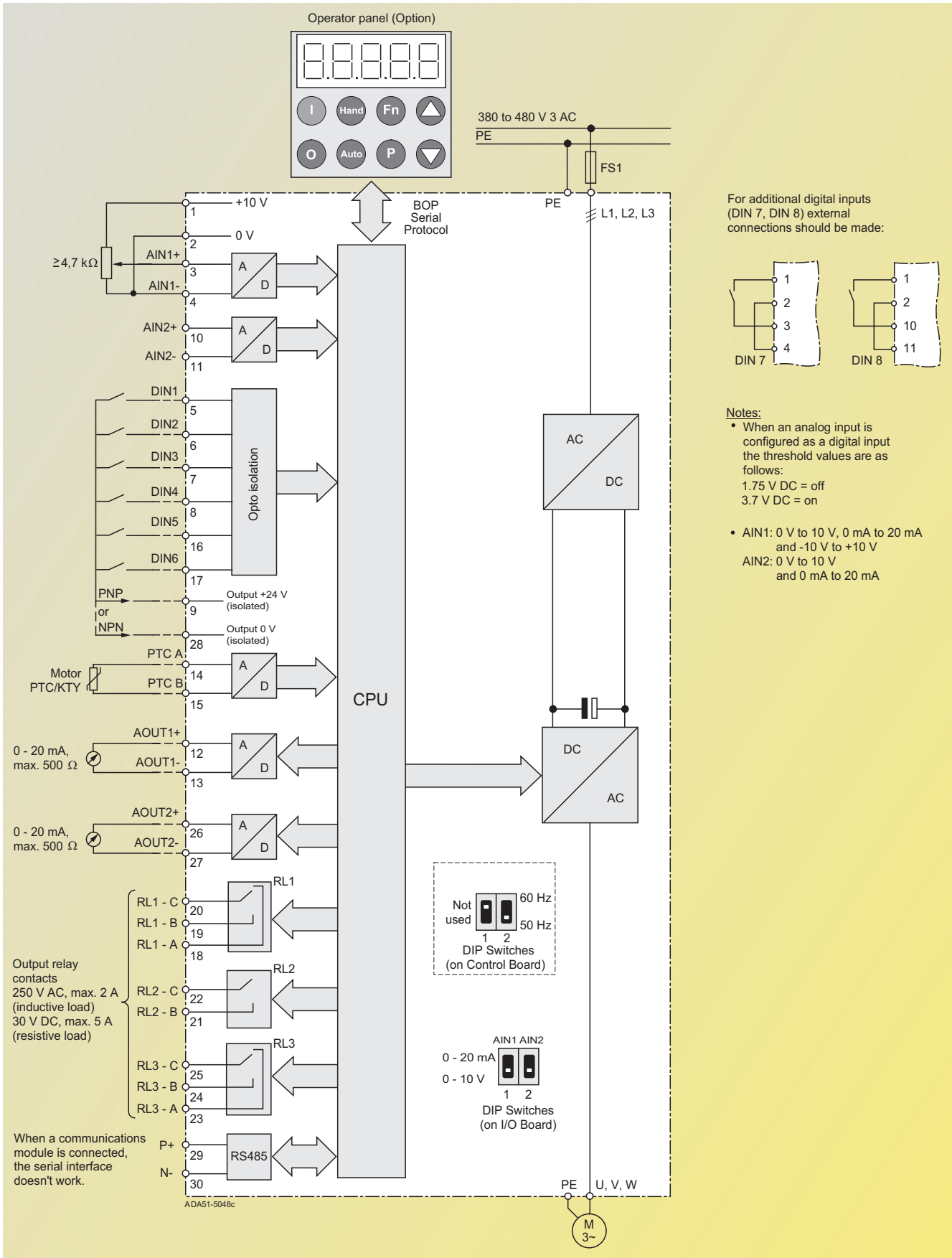

### Terminal connection diagram

Example, frame size C



View A

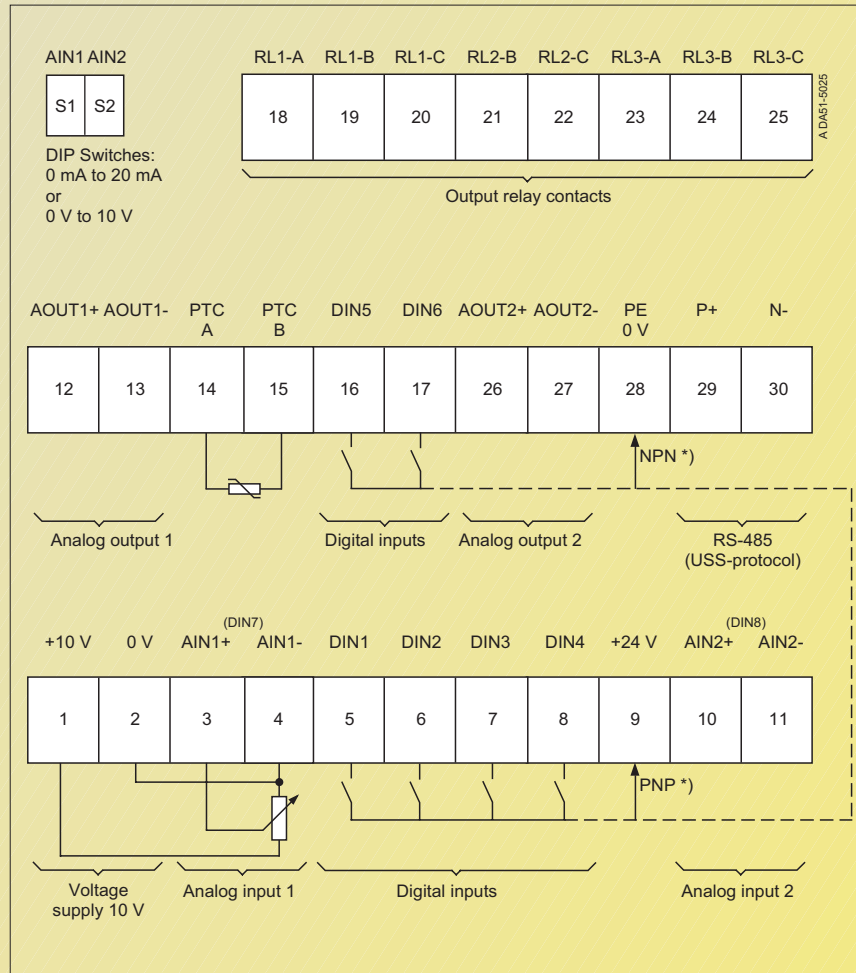

\*) PNP or NPN possible

# MICROMASTER 430

## Technical data

### MICROMASTER 430 inverter

Mains voltage and Power ranges	3 AC 380 V to 480 V ± 10%	7.5 kW to 250 kW (variable torque)
Power frequency	47 Hz to 63 Hz	
Output frequency	7.5 kW to 90 kW 110 kW to 250 kW	0 Hz to 650 Hz 0 Hz to 267 Hz
Power factor	≥ 0.95	
Inverter efficiency	7.5 kW to 90 kW 110 kW to 250 kW	96 % to 97 % 97 % to 98 %
Overload capability	7.5 kW to 90 kW 110 kW to 250 kW	Overload current 1.4 x rated output current (i.e. +140 % overload capability) for 3 s, and 1.1 x rated output current (i.e. 110 % overload capability) for 60 s, cycle time 300 s Overload current 1.5 x rated output current (i.e. 150 % overload capability) for 1 s and 1.1 x rated output current (i.e. 110 % overload capability) for 60 s, cycle time 300 s
Inrush current	Less than rated input current	
Control method	Linear V/f characteristic; quadratic V/f characteristic; multipoint characteristic (programmable V/f characteristic); flux current control (FCC), energy saving mode	
Pulse frequency	7.5 kW to 90 kW 110 kW to 250 kW	4 kHz (standard) 2 kHz to 16 kHz (in 2 kHz steps) 2 kHz (standard) 2 kHz to 4 kHz (in 2 kHz steps)
Fixed frequencies	15, programmable	
Skip frequency ranges	4, programmable	
Setpoint resolution	0.01 Hz digital 0.01 Hz serial 10 bit analog	
Digital inputs	6 fully programmable isolated digital inputs; switchable PNP/NPN	
Analog inputs	2 programmable analog inputs • 0 V to 10 V, 0 mA to 20 mA and -10 V to +10 V (AIN1) • 0 V to 10 V and 0 mA to 20 mA (AIN2) • both can be used as 7th/8th digital input	
Relay outputs	3, programmable, 30 V DC/5 A (resistive load); 250 V AC/2A (inductive load)	
Analog outputs	2, programmable (0/4 mA to 20 mA)	
Serial interfaces	RS-485, optional RS-232	
Motor cable length	7.5 kW to 90 kW without output choke  without output choke 110 kW to 250 kW without output choke  with output choke	max. 50 m (shielded) max. 100 m (unshielded) see variant dependent options  max. 100 m (shielded) max. 150 m (unshielded) Available soon
Electromagnetic compatibility	7.5 kW to 90 kW For inverters without filter 7.5 kW to 15 kW 18.5 kW to 90 kW 110 kW to 250 kW	Inverter with internal filter Class A available  EMC filter, Class B to EN 55 011 available as an option EMC filter, Class B from Schaffner available as an option EMC filter, Class A available as an option
Braking	DC braking, compound braking	
Degree of protection	IP20	
Operating temperature range	7.5 kW to 90 kW 110 kW to 250 kW	-10 °C to +40 °C (+14 °F to +104 °F) 0 °C to +40 °C (+32 °F to +104 °F)
Storage temperature	-40 °C to +70 °C (-40 °F to +158 °F)	
Relative humidity	95 % (non-condensing)	
Installation altitude	7.5 kW to 90 kW 110 kW to 250 kW	Up to 1000 m above sea level without derating Up to 2000 m above sea level without derating
Protection features for	undervoltage, overvoltage, overload, earth faults, short-circuits, stall prevention, locked motor protection, motor overtemperature, inverter overtemperature, parameter change protection	
Conformity with standards	7.5 kW to 90 kW 110 kW to 250 kW	Ⓜ, cⓂ, CE, c-tick  Ⓜ available soon, cⓂ available soon, CE
CE marking	Conformity with low-voltage directive 73/23/EEC	
Dimensions and weights (without options)	Frame size (FS)	H x W x D (mm) Weight, approx. (kg)
	C	245 x 185 x 195 5.7
	D	520 x 275 x 245 17
	E	650 x 275 x 245 22
	F without filter	850 x 350 x 320 56
	F with filter	1150 x 350 x 320 75
	FX	1400 x 326 x 356 116
	GX	1533 x 326 x 545 176

### Derating data

#### Pulse frequency

Output (for 3 AC 400 V) kW	Rated output current in A for a pulse frequency of							
	2 kHz	4 kHz	6 kHz	8 kHz	10 kHz	12 kHz	14 kHz	16 kHz
7.5	19.0	19.0	17.1	15.2	13.3	11.4	9.5	7.6
11.0	26.0	26.0	24.7	23.4	20.8	18.2	15.6	13.0
15.0	32.0	32.0	28.8	25.6	22.4	19.2	16.0	12.8
18.5	38.0	38.0	36.1	34.2	30.4	26.6	22.8	19.0
22	45.0	45.0	40.5	36.0	31.5	27.0	22.5	18.0
30	62.0	62.0	55.8	49.6	43.4	37.2	31.0	24.8
37	75.0	75.0	71.3	67.5	60.0	52.5	45.0	37.5
45	90.0	90.0	81.0	72.0	63.0	54.0	45.0	36.0
55	110.0	110.0	93.5	77.0	63.3	49.5	41.3	33.0
75	145.0	145.0	123.3	101.5	83.4	65.3	54.4	43.5
90	178.0	178.0	138.0	97.9	84.6	71.2	62.3	53.4
110	205.0	180.4	–	–	–	–	–	–
132	250.0	220.0	–	–	–	–	–	–
160	302.0	265.8	–	–	–	–	–	–
200	370.0	325.6	–	–	–	–	–	–
250	477.0	419.8	–	–	–	–	–	–

#### Operating temperature

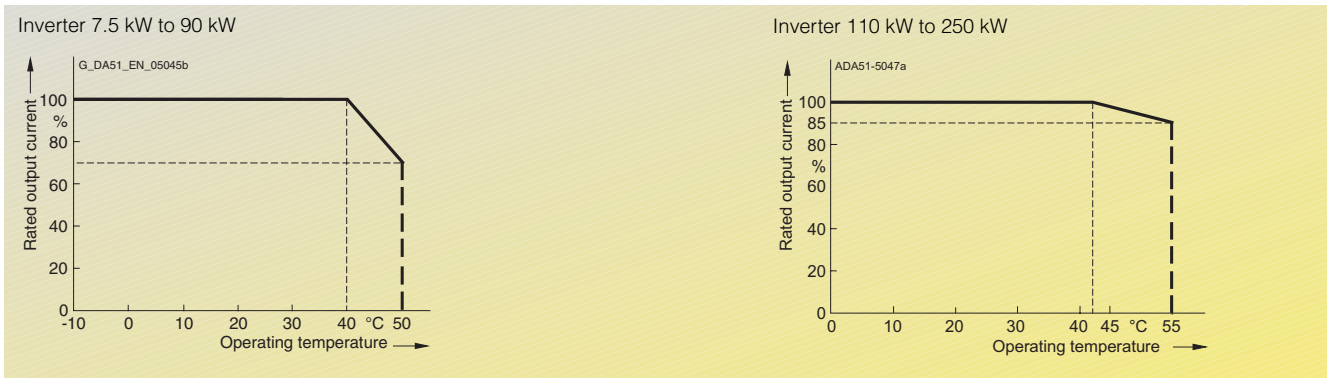

## Technical data

### Derating data (continued)

#### Installation height above sea level

Permissible output current  
in % of the rated output current  
Inverter 7.5 kW to 90 kW

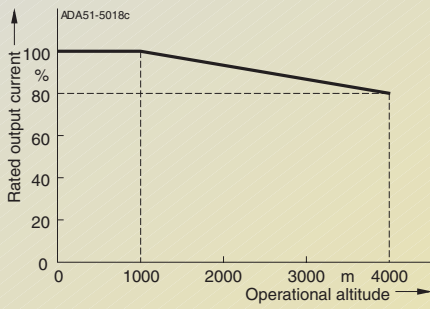

Inverter 110 kW to 250 kW

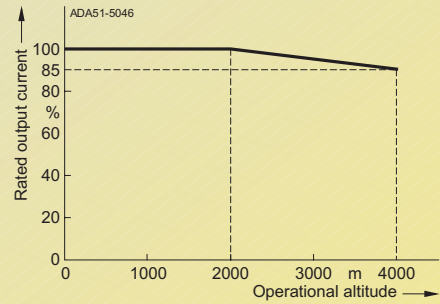

Permissible mains voltage  
in % of the max. possible mains voltage  
Inverter 7.5 kW to 90 kW

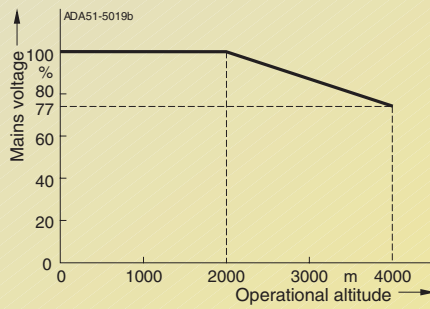

Inverter 110 kW to 250 kW

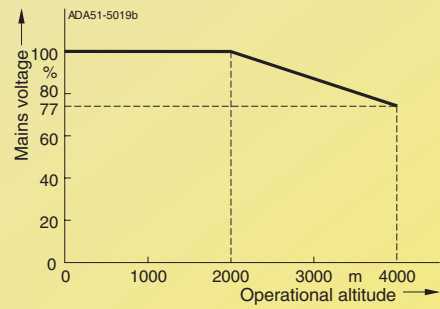

3

### MICROMASTER 430 inverter

Output		Rated input current	Rated output current	Frame size	Order No.	
kW	hp	A	A	(FS)	MICROMASTER 430 without filter <sup>4)</sup>	MICROMASTER 430 with internal filter Class A <sup>3)</sup>
<b>Mains operating voltage 3 AC 380 V to 480 V</b>						
7.5	10	20.2 <sup>1)</sup>	19	C	6SE6430-2UD27-5CA0	6SE6430-2AD27-5CA0
11.0	15	29.0 <sup>1)</sup>	26	C	6SE6430-2UD31-1CA0	6SE6430-2AD31-1CA0
15.0	20	39.0 <sup>1)</sup>	32	C	6SE6430-2UD31-5CA0	6SE6430-2AD31-5CA0
18.5	25	45.2 <sup>1)</sup>	38	D	6SE6430-2UD31-8DA0	6SE6430-2AD31-8DA0
22	30	54.7 <sup>1)</sup>	45	D	6SE6430-2UD32-2DA0	6SE6430-2AD32-2DA0
30	40	74.8 <sup>1)</sup>	62	D	6SE6430-2UD33-0DA0	6SE6430-2AD33-0DA0
37	50	91.0 <sup>1)</sup>	75	E	6SE6430-2UD33-7EA0	6SE6430-2AD33-7EA0
45	60	111.0 <sup>1)</sup>	90	E	6SE6430-2UD34-5EA0	6SE6430-2AD34-5EA0
55	75	143.0 <sup>1)</sup>	110	F	6SE6430-2UD35-5FA0	6SE6430-2AD35-5FA0
75	100	190.0 <sup>1)</sup>	145	F	6SE6430-2UD37-5FA0	6SE6430-2AD37-5FA0
90	120	223.0 <sup>1)</sup>	178	F	6SE6430-2UD38-8FA0	6SE6430-2AD38-8FA0
110	150	204.5 <sup>2)</sup>	205	FX	6SE6430-2UD41-1FA0	–
132	200	244.5 <sup>2)</sup>	250	FX	6SE6430-2UD41-3FA0	–
160	250	296.4 <sup>2)</sup>	302	GX	6SE6430-2UD41-6GA0	–
200	300	354.0 <sup>2)</sup>	370	GX	6SE6430-2UD42-0GA0	–
250	350	442.0 <sup>2)</sup>	477	GX	6SE6430-2UD42-5GA0	–



See Appendix for note on ordering.

All MICROMASTER 430 inverters are supplied with a Status Display Panel (SDP). A BOP-2 or other options have to be ordered separately (see Pages 3/11 to 3/13).

### Motors for MICROMASTER 430

Catalog M 11 contains selection and ordering data for motors which are particularly suitable for operation with the MICROMASTER 430 inverters (see Appendix for overview).

This catalog is suitable for IEC motors. For motors according to US standards (NEMA) please refer to: <http://www.sea.siemens.com/motors>

1) Supplementary conditions: Input current at rated operating point, applicable at short-circuit voltage of the supply  $U_{SC} = 1\%$  with reference to the inverter rated power and rated mains operating voltage of 400 V without a line commutating choke.

If a line commutating choke is used, the specified values at 380 V to 480 V are reduced to between 70% and 80%

2) Supplementary conditions: Input current at rated operating point, applicable at short-circuit voltage of the supply  $U_{SC} \geq 2.33\%$  with reference to the inverter rated power and rated mains voltage of 400 V.

3) Use of MICROMASTER inverters with internal filter is not permissible on non-grounded mains supplies.

4) Generally suited to heavy industrial applications. For details please refer to Appendix on page A/4.

## Options Variant dependent options

### Overview

#### EMC filter, Class A

All 7.5 kW to 90 kW inverters are supplied with an internal filter Class A.

For inverters 110 kW to 250 kW, EMC filters Class A are available. In this performance range, the EMC filters are only permitted to be used in combination with a line commutating choke.

The requirements are fulfilled using shielded cables with a max. length of 25 m.

#### EMC filter, Class B

Available for inverters 7.5 kW to 15 kW with an internal Class A EMC filter.

The requirements are fulfilled using shielded cables with a max. length of 25 m.

For inverters 18.5 kW to 90 kW without filters, EMC filters of Class B from Schaffner can be used.

The requirements are fulfilled using shielded cables with a max. length of 25 m to 50 m (depending on the type, details on request).

With this filter, the inverter complies with the emission standard EN 55 011, Class B.

#### Leakage currents:

The leakage currents of the inverters with/without filter (internal/external) may exceed 30 mA. Typical values in practice are between 10 mA and

50 mA. The exact values depend on the design, environment and cable lengths. Interference-free operation with residual current operated devices with a trigger value of 30 mA cannot be guaranteed.

However, operation with residual current operated devices with a trigger value of 300 mA is possible. Please refer to the Instruction Manual for details.

#### LC filter

The LC filter limits the rate of rise of voltage and the capacitive charge/discharge currents which usually occur with inverter operation. This means that much longer shielded motor cables are possible when using LC filters and the service life of the motor achieves values similar to those with direct mains operation.

The LC filters can be used for all MICROMASTER 430 inverters of frame sizes C to F.

- Frame size C:  
Only one footprint component is permissible for frame size C. If a line choke and LC filter are used, the line choke must be located on the left of the inverter. Required spacing: 75 mm.

- Frame sizes D to F:  
The LC filters, frame sizes D to F, are designed for mounting upright in the control cabinet. Due to leakage flux lines caused by physical sources, a minimum distance of 50 mm to adjacent modules and metal parts is recommended.

Please note when using LC filters:

- Only V/f, FCC control permissible
- Increased inverter load: approx. 10% to 15%
- Operation only permissible with 4 kHz pulse frequency
- The output frequency is limited to 150 Hz.

#### Line commutating choke

Line commutating chokes are used to smooth voltage peaks or to bridge commutating dips.

In addition, line commutating chokes reduce the effects of harmonics on the inverter and the power supply. If the line impedance is < 1 %, a line commutating choke must be used in order to reduce the current peaks.

No limits are currently defined in the EN 61 000-3-2 standard for professionally used devices with a connected load > 1 kW.

This means that the inverters with an output power  $\geq 0.75$  kW comply with the EN 61 000-3-2 standard.

#### Output choke

Output chokes can be supplied for reducing the capacitive compensation currents and  $dV/dt$  in the case of motor cables >50 m (shielded) or > 100 m (unshielded).

For max. permissible cable lengths, see Technical Data.

#### Gland plate

Gland plates are available for inverters of frame size C. In frame sizes D, E and F, the gland plates are integrated.

The gland plate facilitates the shield connection of power and control cables and thus ensure optimum EMC performance.

## Technical data

### LC filter

Mains voltage	3 AC 380 V to 480 V		
Current at (40 °C / 50 °C)			
For frame size C (7.5 to 15 kW)	32.6 A/ 29.7 A		
For frame size D (18.5 kW)	38.8 A/ 32 A		
For frame size D (22 kW)	45.9 A/ 38 A		
For frame size D (30 kW)	63.2 A/ 45 A		
For frame size E (37 kW)	76.5 A/ 62 A		
For frame size E (45 kW)	112.2 A/ 90 A		
For frame size F (55 kW)	112.2 A/ 90 A		
For frame size F (75 kW)	147.9 A/110 A		
For frame size F (90 kW)	181.6 A/145 A		
Limiting of motor overvoltage	≤ 1078 V		
dV/dt limiting	≤ 500 V/μs		
Pulse frequency	4 kHz		
Max. motor frequency	150 Hz		
Max. permissible motor cable lengths	Shielded	200 m	
	Unshielded	300 m	
Insulation strength	Overvoltage category III to VDE 0110		
Electromagnetic compatibility	Up to 200 m motor cable length with emissions to Class A according to EN 55 011 in conjunction with filtered inverters and unshielded cables		
Conformity	CE according to the low-voltage directive 73/23/EEC		
Approvals	UL available soon		
Strain resistance	EN 60 068-2-31		
Humidity	95 % humidity, non-condensing		
Degree of protection	Frame size C	IP20 (to EN 60 529)	
	Frame sizes D to F	IP00 / IP20 (to EN 60 529 with terminal covers)	
Insulation class	H (180 °C)		
Temperature range	Operation	-10 °C to +40 °C (+14 °F to +104 °F) to +50 °C (to +122 °F)	100 % P <sub>n</sub> 80 % P <sub>n</sub>
	Storage	-25 °C to +70 °C (-13 °F to +158 °F)	
Installation altitude	Frame size C	Up to 2000 m: 100 % P <sub>n</sub> 2000 to 4000 m: 62.5 % P <sub>n</sub>	
	Frame sizes D to F	to 1000 m: 100 % P <sub>n</sub> 1000 to 4000 m: 12.5 % derating for each 1000 m	
Mounting position	Vertical		
Free space	100 mm 100 mm 100 mm		
Connection system	Input, litz wire or terminal	1U1, 1V1, 1W1	
	Output, terminals	1U2, 1V2, 1W2	
Torque for conductor connections	Frame size C	Terminal cross-section	Torque
	Frame sizes D to F	–	1.5 Nm to 1.8 Nm
		16 mm <sup>2</sup>	2.0 Nm to 4.0 Nm
		35 mm <sup>2</sup>	2.5 Nm to 5.0 Nm
		50 mm <sup>2</sup>	3.0 Nm to 6.0 Nm
		95 mm <sup>2</sup>	6.0 Nm to 12.0 Nm
		150 mm <sup>2</sup>	10.0 Nm to 20.0 Nm
Weight, approx.	for frame size C	29 kg	
	for frame size D	21 kg to 34 kg	
	for frame size E	49.5 kg to 67 kg	
	for frame size F	67 kg to 77.5 kg	

### Max. permissible cable lengths from the motor to the inverter when using output chokes

The following table shows the maximum permissible cable lengths from the motor to the inverter when using output chokes.

Frame size	Output choke	Max. permissible motor cable lengths (shielded/unshielded) for a mains voltage of	
(FS)	Type	380 V to 400 V ± 10 %	401 V to 480 V ± 10 %
C	6SE6400-3TC03-2CD3	200 m/300 m	100 m/150 m
D to F	6SE6400-3TC . . . . D0	200 m/300 m	200 m/300 m
FX/GX	Available soon		



# MICROMASTER 430

## Options Variant dependent options

### Selection and ordering data

The options listed here (filters, chokes, gland plates, fuses and circuit-breakers) must be selected to match the inverter.

The inverter and the associated options have the same voltage ratings.

**All options are certified to , except fuses. The 3NE1 fuses are -listed (equivalent to ).**

● Use in America requires -listed fuses such as the Class NON range from Bussmann.

Mains voltage	Output		Inverter without filter	Order No. of the options		
	kW	hp		EMC filter, Class A	EMC filter, Class B	LC filter
<b>3 AC 380 V to 480 V</b>	7.5	10	6SE6430-2UD27-5CA0	–	–	<b>6SE6400-3TD03-2CD0</b>
	11.0	15	6SE6430-2UD31-1CA0	–	–	
	15.0	20	6SE6430-2UD31-5CA0	–	–	
	18.5	25	6SE6430-2UD31-8DA0	–	EMC filter, Class B, available from Schaffner	<b>6SE6400-3TD03-7DD0</b>
	22	30	6SE6430-2UD32-2DA0	–		<b>6SE6400-3TD04-8DD0</b>
	30	40	6SE6430-2UD33-0DA0	–		<b>6SE6400-3TD06-1DD0</b>
	37	50	6SE6430-2UD33-7EA0	–		<b>6SE6400-3TD07-2ED0</b>
	45	60	6SE6430-2UD34-5EA0	–		<b>6SE6400-3TD11-5FD0</b>
	55	75	6SE6430-2UD35-5FA0	–		
	75	100	6SE6430-2UD37-5FA0	–		<b>6SE6400-3TD15-0FD0</b>
	90	120	6SE6430-2UD38-8FA0	–		<b>6SE6400-3TD18-0FD0</b>
	110	150	6SE6430-2UD41-1FA0	<b>6SL3000-0BE32-5AA0 *)</b>	–	Available soon
	132	200	6SE6430-2UD41-3FA0	<b>6SL3000-0BE34-4AA0 *)</b>	–	
	160	250	6SE6430-2UD41-6GA0	–	–	
	200	300	6SE6430-2UD42-0GA0	–	–	
250	350	6SE6430-2UD42-5GA0	<b>6SL3000-0BE36-0AA0 *)</b>	–		

\*) Must be used in combination with a line commutating choke.

Mains voltage	Output		Inverter without filter	Order No. of the options		
	kW	hp		Line commutating choke	Output choke	Gland plate
<b>3 AC 380 V to 480 V</b>	7.5	10	6SE6430-2UD27-5CA0	<b>6SE6400-3CC02-2CD3</b>	<b>6SE6400-3TC03-2CD3</b>	<b>6SE6400-0GP00-0CA0</b>
	11.0	15	6SE6430-2UD31-1CA0			
	15.0	20	6SE6430-2UD31-5CA0	<b>6SE6400-3CC03-5CD3</b>		
	18.5	25	6SE6430-2UD31-8DA0	<b>6SE6400-3CC04-4DD0</b>	<b>6SE6400-3TC05-4DD0</b>	Integrated as standard
	22	30	6SE6430-2UD32-2DA0		<b>6SE6400-3TC03-8DD0</b>	
	30	40	6SE6430-2UD33-0DA0	<b>6SE6400-3CC05-2DD0</b>	<b>6SE6400-3TC05-4DD0</b>	
	37	50	6SE6430-2UD33-7EA0	<b>6SE6400-3CC08-3ED0</b>	<b>6SE6400-3TC08-0ED0</b>	
	45	60	6SE6430-2UD34-5EA0		<b>6SE6400-3TC07-5ED0</b>	
	55	75	6SE6430-2UD35-5FA0	<b>6SE6400-3CC11-2FD0</b>	<b>6SE6400-3TC14-5FD0</b>	
	75	100	6SE6430-2UD37-5FA0		<b>6SE6400-3TC15-4FD0</b>	
	90	120	6SE6430-2UD38-8FA0	<b>6SE6400-3CC11-7FD0</b>	<b>6SE6400-3TC14-5FD0</b>	
	110	150	6SE6430-2UD41-1FA0	<b>6SL3000-0CE32-3AA0</b>	Available soon	
	132	200	6SE6430-2UD41-3FA0	<b>6SL3000-0CE32-8AA0</b>		
	160	250	6SE6430-2UD41-6GA0	<b>6SL3000-0CE33-3AA0</b>		
	200	300	6SE6430-2UD42-0GA0	<b>6SL3000-0CE35-1AA0</b>		
250	350	6SE6430-2UD42-5GA0				

Mains voltage	Output		Inverter without filter	Order No. of the options		Circuit-breaker (see Catalog LV 10)
	kW	hp		Fuses (see Catalog LV 10)		
<b>3 AC 380 V to 480 V</b>	7.5	10	6SE6430-2UD27-5CA0	<b>3NA3</b>	<b>3NE1 (  )</b>	<b>3RV1031-4EA10</b>
	11.0	15	6SE6430-2UD31-1CA0	<b>3NA3807</b>	●	<b>3RV1031-4FA10</b>
	15.0	20	6SE6430-2UD31-5CA0	<b>3NA3812</b>		<b>3RV1031-4HA10</b>
	18.5	25	6SE6430-2UD31-8DA0	<b>3NA3814</b>		<b>3RV1042-4KA10</b>
	22	30	6SE6430-2UD32-2DA0	<b>3NA3820</b>	<b>3NE1817-0</b>	
	30	40	6SE6430-2UD33-0DA0	<b>3NA3822</b>	<b>3NE1818-0</b>	
	37	50	6SE6430-2UD33-7EA0	<b>3NA3824</b>	<b>3NE1820-0</b>	<b>3RV1042-4MA10</b>
	45	60	6SE6430-2UD34-5EA0	<b>3NA3830</b>	<b>3NE1021-0</b>	<b>3VL1712-.DD33-....</b>
	55	75	6SE6430-2UD35-5FA0	<b>3NA3832</b>	<b>3NE1022-0</b>	<b>3VL1716-.DD33-....</b>
	75	100	6SE6430-2UD37-5FA0	<b>3NA3836</b>	<b>3NE1224-0</b>	<b>3VL3720-.DC36-....</b>
	90	120	6SE6430-2UD38-8FA0	<b>3NA3140</b>	<b>3NE1225-0</b>	<b>3VL3725-.DC36-....</b>
	110	150	6SE6430-2UD38-8FA0	<b>3NA3144</b>	<b>3NE1227-0</b>	<b>3VL4731-.DC36-....</b>
	132	200	6SE6430-2UD41-1FA0	–		On request
	160	250	6SE6430-2UD41-3FA0	–	<b>3NE1230-0</b>	
	200	300	6SE6430-2UD41-6GA0	–	<b>3NE1332-0</b>	
250	350	6SE6430-2UD42-0GA0	–	<b>3NE1333-0</b>		
250	350	6SE6430-2UD42-5GA0	–	<b>3NE1435-0</b>		

## Selection and ordering data (continued)

Mains voltage	Output		Inverter with internal filter Class A	Order No. of the options		
	kW	hp		LC filter	Line commutating choke	Output choke
3 AC 380 V to 480 V	7.5	10	6SE6430-2AD27-5CA0	6SE6400-3TD03-2CD0	6SE6400-3CC02-2CD3	6SE6400-3TC03-2CD3
	11.0	15	6SE6430-2AD31-1CA0			
	15.0	20	6SE6430-2AD31-5CA0	6SE6400-3CC03-5CD3		
	18.5	25	6SE6430-2AD31-8DA0	6SE6400-3TD03-7DD0	6SE6400-3CC04-4DD0	6SE6400-3TC05-4DD0
	22	30	6SE6430-2AD32-2DA0	6SE6400-3TD04-8DD0	6SE6400-3TC03-8DD0	
	30	40	6SE6430-2AD33-0DA0	6SE6400-3TD06-1DD0	6SE6400-3CC05-2DD0	6SE6400-3TC05-4DD0
	37	50	6SE6430-2AD33-7EA0	6SE6400-3TD07-2ED0	6SE6400-3CC08-3ED0	6SE6400-3TC08-0ED0
	45	60	6SE6430-2AD34-5EA0	6SE6400-3TD11-5FD0	6SE6400-3TC07-5ED0	
	55	75	6SE6430-2AD35-5FA0	6SE6400-3CC11-2FD0		6SE6400-3TC14-5FD0
	75	100	6SE6430-2AD37-5FA0	6SE6400-3TD15-0FD0	6SE6400-3TC15-4FD0	
90	120	6SE6430-2AD38-8FA0	6SE6400-3TD18-0FD0	6SE6400-3CC11-7FD0	6SE6400-3TC14-5FD0	

Mains voltage	Output		Inverter with internal filter Class A	Order No. of the options	
	kW	hp		Additional EMC filter, Class B	Gland plate
3 AC 380 V to 480 V	7.5	10	6SE6430-2AD27-5CA0	6SE6400-2FS03-8CD0	6SE6400-0GP00-0CA0
	11.0	15	6SE6430-2AD31-1CA0	An inverter <b>without</b> filter must be selected to satisfy the EMC requirements of Class B. In addition, an appropriate EMC filter of Class B is from Schaffner is required.	
	15.0	20	6SE6430-2AD31-5CA0		
	18.5	25	6SE6430-2AD31-8DA0		
	22	30	6SE6430-2AD32-2DA0		
	30	40	6SE6430-2AD33-0DA0		
	37	50	6SE6430-2AD33-7EA0		
	45	60	6SE6430-2AD34-5EA0		
	55	75	6SE6430-2AD35-5FA0		
	75	100	6SE6430-2AD37-5FA0		
90	120	6SE6430-2AD38-8FA0	Integrated as standard		

Mains voltage	Output		Inverter with internal filter Class A	Order No. of the options		Circuit-breaker (see Catalog LV 10)
	kW	hp		Fuses (see Catalog LV 10)		
3 AC 380 V to 480 V	7.5	10	6SE6430-2AD27-5CA0	3NA3807	●	3RV1031-4EA10
	11.0	15	6SE6430-2AD31-1CA0	3NA3812		3RV1031-4FA10
	15.0	20	6SE6430-2AD31-5CA0	3NA3814		3RV1031-4HA10
	18.5	25	6SE6430-2AD31-8DA0	3NA3820	3NE1817-0	3RV1042-4KA10
	22	30	6SE6430-2AD32-2DA0	3NA3822	3NE1818-0	
	30	40	6SE6430-2AD33-0DA0	3NA3824	3NE1820-0	3RV1042-4MA10
	37	50	6SE6430-2AD33-7EA0	3NA3830	3NE1021-0	3VL1712-.DD33-....
	45	60	6SE6430-2AD34-5EA0	3NA3832	3NE1022-0	3VL1716-.DD33-....
	55	75	6SE6430-2AD35-5FA0	3NA3836	3NE1224-0	3VL3720-.DC36-....
	75	100	6SE6430-2AD37-5FA0	3NA3140	3NE1225-0	3VL3725-.DC36-....
90	120	6SE6430-2AD38-8FA0	3NA3144	3NE1227-0	3VL4731-.DC36-....	

● Use in America requires Ⓜ-listed fuses such as the Class NON range from Bussmann.

## Options

### Variant independent options

#### Overview

##### Basic Operator Panel 2 (BOP-2)

With the BOP-2, individual parameter settings can be made. Values and units are shown on a 5-digit display.



Basic Operator Panel (BOP-2)

A BOP-2 can be used for several inverters. It can be directly mounted on the inverter or in a control cabinet door using a mounting kit.

##### PROFIBUS module

For a complete PROFIBUS connection with up to  $\leq 12$  Mbaud. Remote control of the inverter is possible with the PROFIBUS module. Remote control and operation at the inverter can be combined using an operator panel plugged onto the PROFIBUS module. The PROFIBUS module can be supplied by an external 24 V DC power supply and is thus also active when the inverter is disconnected from the power supply.

Connection by means of a 9-pin Sub-D connector (available as an option).

##### DeviceNet module

For networking the inverters to the DeviceNet fieldbus system widely used on the American market. A maximum transmission rate of 500 kbaud is possible. Remote control of the inverter is possible with the DeviceNet module.

Remote control and operation at the inverter can be combined using an operator panel plugged onto the DeviceNet module.

The connection to the DeviceNet bus system is made using a 5-pin connector with terminal strip.

##### CANopen module

Using the CANopen communications module, an inverter can be linked to the CANopen fieldbus system and remote control is then possible.

Remote control and operation at the inverter can be combined using an operator panel plugged onto the CANopen module.

The module is connected to the bus system through a 9-pin Sub-D connector.

##### Connection kit for PC to inverter

For controlling an inverter directly from a PC if the appropriate software has been installed (e.g. STARTER). Isolated RS-232 adapter module for reliable point-to-point connection to a PC. Includes a Sub-D connector and an RS-232 standard cable (3 m).

##### Operator panel door mounting kit for single inverter

For mounting an operator panel BOP-2 in a control cabinet door. Degree of protection IP56. Contains a cable adapter module with screwless terminals for use with user's own RS-232 cables <sup>1)</sup>.

##### Start-up tools

- **STARTER** is a graphic start-up software for guided start-up for MICROMASTER 410/420/430/440 frequency inverters under Windows NT/2000/XP Professional. Parameter lists can be read out, altered, stored, entered and printed.
- **DriveMonitor** is a start-up software for list-oriented programming of frequency inverters. This program executes under Windows 95/98/NT/2000/XP Professional.

Both programs are included on the Docu CD which is provided with every inverter.

1) A shielded cable of type Belden 8132 (28 AWG) is recommended. The maximum cable length is 5 m for RS-232.

#### Selection and ordering data

The options listed here are suitable for all MICROMASTER 430 inverters.

Options	Order No.
Basic Operator Panel 2 (BOP-2)	<b>6SE6400-0BE00-0AA0</b>
PROFIBUS module	<b>6SE6400-1PB00-0AA0</b>
DeviceNet module	<b>6SE6400-1DN00-0AA0</b>
CANopen module	<b>6SE6400-1CB00-0AA0</b>
RS485/PROFIBUS bus connector	<b>6GK1500-0FC00</b>
Connection kit for PC to inverter	<b>6SE6400-1PC00-0AA0</b>
Operator panel door mounting kit for single inverter	<b>6SE6400-0PM00-0AA0</b>

## Technical data of the communication modules

**PROFIBUS module**  
6SE6400-1PB00-0AA0



**DeviceNet module**  
6SE6400-1DN00-0AA0



Size (height x width x depth)	161 mm x 73 mm x 46 mm	
Degree of protection	IP20	
Degree of pollution	2 to IEC 60 664-1 (DIN VDE 01 10/T1), no condensation permitted during operation	
Strain resistance	to IEC 60068-2-6 (if module is installed correctly)	
• Stationary	Deflection	0.15 mm in the frequency range of 10 Hz to 58 Hz
	Acceleration	19.6 m/s <sup>2</sup> in the frequency range of 58 Hz to 500 Hz
• Transport	Deflection	3.5 mm in the frequency range of 5 Hz to 9 Hz
	Acceleration	9.8 m/s <sup>2</sup> in the frequency range of 9 Hz to 500 Hz
Climatic category (during operation)	3K3 to IEC 60 721-3-3	
Cooling method	Natural air cooling	
Permissible ambient or cooling agent temperature	-10 °C to +50 °C (+14 °F to +122 °F)	
• Operation	-25 °C to +70 °C (-13 °F to +158 °F)	
• Storage and transport		
Relative humidity (permissible humidity rating)	≤ 85 % (non-condensing)	
• Operation	≤ 95 %	
• Storage and transport		
Electromagnetic compatibility	Emission	to EN 55 011 (1991) Class A
	Interference	to IEC 60 801-3 and EN 61 000-4-3
Power supply	6.5 V ± 5 %, max. 300 mA, internal from inverter or 24 V ± 10 %, max. 350 mA, external	6.5 V ± 5 %, max. 300 mA internal from inverter or 24 V, max. 60 mA from DeviceNet-Bus
Output voltage	5 V ± 10 %, max. 100 mA, galvanically isolated supply • for terminating the serial interface bus or • for supplying the OLP (Optical Link Plug)	–
Data transmission rate	max. 12 Mbaud	125, 250 and 500 Kbaud

## Options

### Variant independent options

#### Technical data of the communication modules (continued)

**CANopen module**  
6SE6400-1CB00-0AA0



Size (height x width x depth)	161 mm x 73 mm x 46 mm
Degree of protection	IP20
Degree of pollution	2 to IEC 60 664-1 (DIN VDE 0110/T1), no condensation permitted during operation
Strain resistance	to IEC 60 068-2-6 (if module is installed correctly)
• Stationary	Deflection 0.15 mm in the frequency range of 10 Hz to 58 Hz Acceleration 19.6 m/s <sup>2</sup> in the frequency range of 58 Hz to 500 Hz
• Transport	Deflection 3.5 mm in the frequency range of 5 Hz to 9 Hz Acceleration 9.8 m/s <sup>2</sup> in the frequency range of 9 Hz to 500 Hz
Climatic category (during operation)	3K3 to IEC 60 721-3-3
Cooling method	Natural air cooling
Permissible ambient or cooling agent temperature	
• Operation	-10 °C to +50 °C (+14 °F to +122 °F)
• Storage	-40 °C to +70 °C (-40 °F to +158 °F)
• Transport	-25 °C to +70 °C (-13 °F to +158 °F)
Relative humidity (permissible humidity rating)	
• Operation	≤ 85 % (non-condensing)
• Storage and transport	≤ 95 %
Power supply	The CAN bus is supplied from the inverter power supply
Data transmission rate	10, 20, 50, 125, 250, 500, 800 Kbaud and 1 Mbaud

## Documentation

### Selection and ordering data

Type of documentation	Language	Order No.
<b>Docu pack</b> , supplied with each inverter, containing CD-ROM <sup>1)</sup> and Getting Started Guide <sup>2)</sup> (paper version)	Multilanguage	<b>6SE6400-5AE00-1AP0</b>
<b>Operating instructions<sup>2)</sup></b> (paper version)	German	<b>6SE6400-5AE00-0AP0</b>
	English	<b>6SE6400-5AE00-0BP0</b>
	French	<b>6SE6400-5AE00-0DP0</b>
	Italian	<b>6SE6400-5AE00-0CP0</b>
	Spanish	<b>6SE6400-5AE00-0EP0</b>
<b>Parameter list<sup>2)</sup></b> (paper version)	German	<b>6SE6400-5AF00-0AP0</b>
	English	<b>6SE6400-5AF00-0BP0</b>
	French	<b>6SE6400-5AF00-0DP0</b>
	Italian	<b>6SE6400-5AF00-0CP0</b>
	Spanish	<b>6SE6400-5AF00-0EP0</b>

1) The CD-ROM contains operating instructions, parameter list, commissioning tools STARTER

and DriveMonitor, multilanguage

2) Available on Internet at <http://www.siemens.com/micromaster>

### MICROMASTER 430 inverter

Frame size	3 AC 380 V to 480 V
<b>C</b>	7.5 kW to 15 kW
<b>D</b>	18.5 kW to 30 kW
<b>E</b>	37 kW to 45 kW

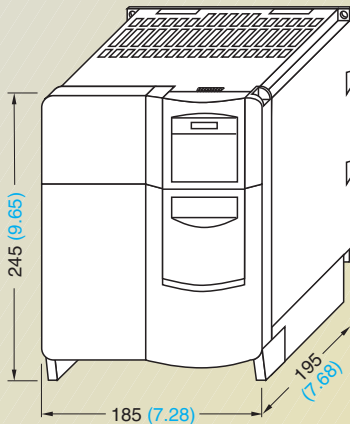

Inverter frame size **C**

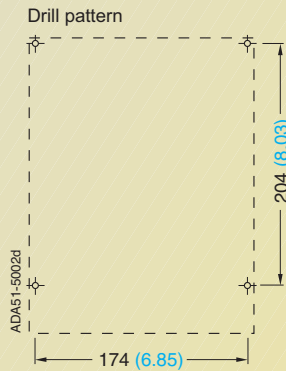

Fixing with  
 4 x M5 bolts  
 4 x M5 nuts  
 4 x M5 washers  
 Tightening torque with washers fitted:  
 3.0 Nm  
 Ventilation clearance required at top  
 and bottom: 100 mm

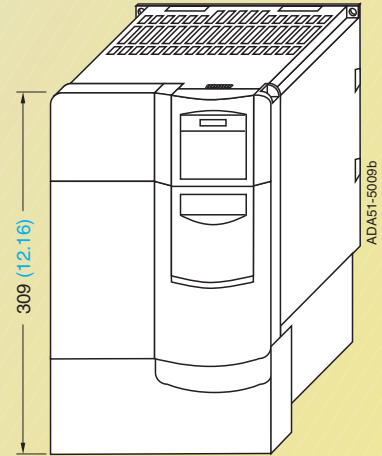

Inverter frame size **C**  
 with **gland plate**

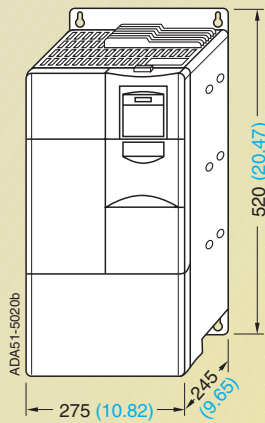

Inverter frame size **D**

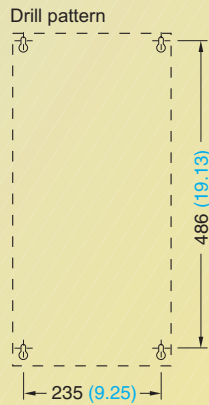

Fixing with  
 4 x M8 bolts  
 4 x M8 nuts  
 4 x M8 washers  
 Tightening torque with  
 washers fitted: 3.0 Nm  
 Ventilation clearance  
 required at top and bottom:  
 300 mm

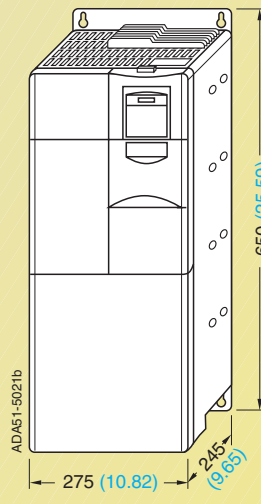

Inverter frame size **E**

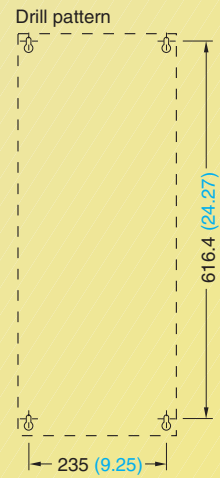

Fixing with  
 4 x M8 bolts  
 4 x M8 nuts  
 4 x M8 washers  
 Tightening torque with  
 washers fitted: 3.0 Nm  
 Ventilation clearance  
 required at top and bottom:  
 300 mm

With the communication module, the mounting depth increases  
 for frame size C by 23 mm (0.91 inches).

All dimensions in mm (values in brackets are in inches)

# MICROMASTER 430

## Dimension drawings

### MICROMASTER 430 inverter

Frame size	3 AC 380 V to 480 V
<b>F</b>	55 kW to 90 kW

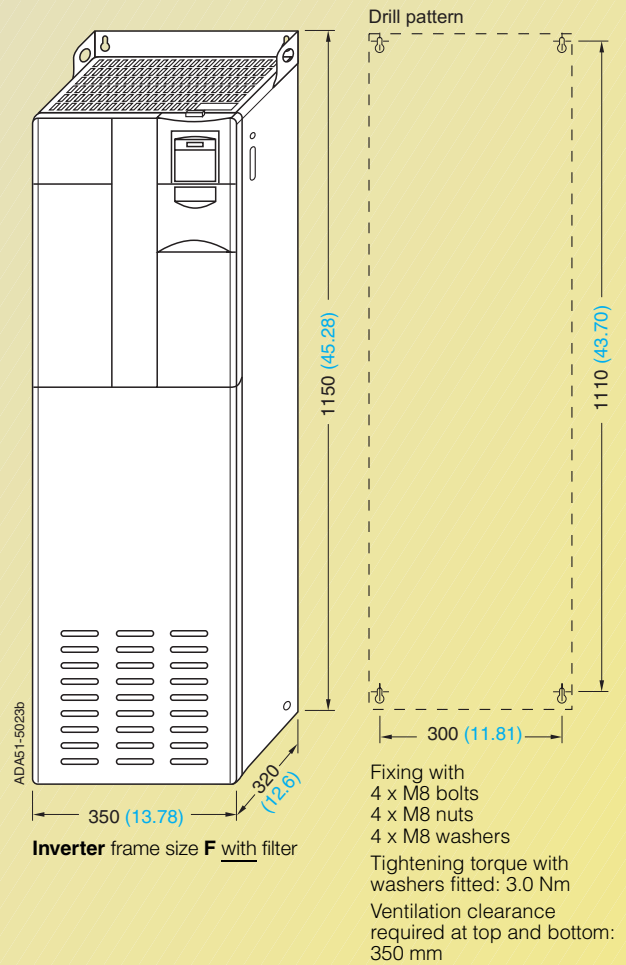
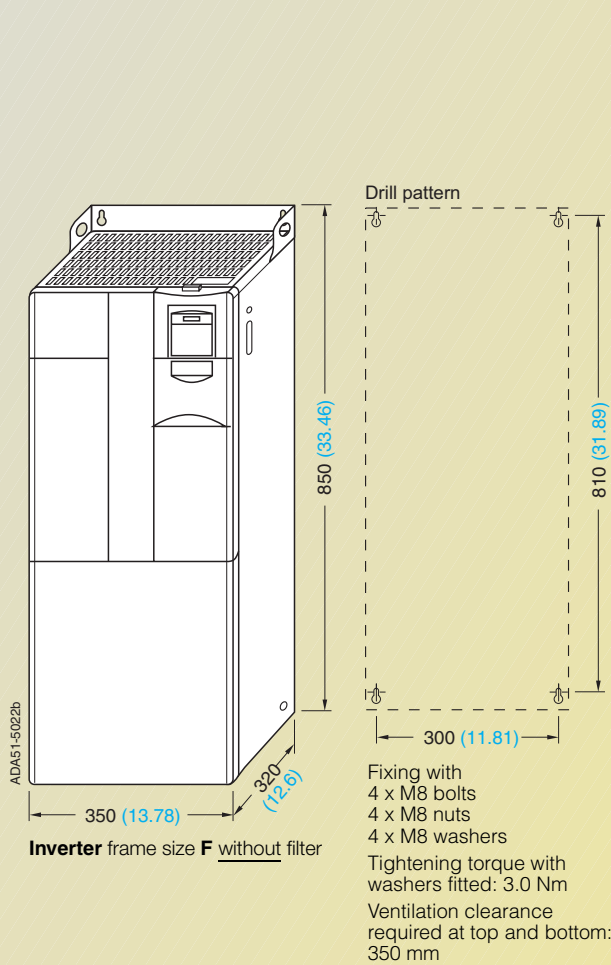

All dimensions in mm (values in brackets are in inches)

### MICROMASTER 430 inverter

Frame size	3 AC 380 V to 480 V
<b>FX</b>	110 kW to 132 kW
<b>GX</b>	160 kW to 250 kW

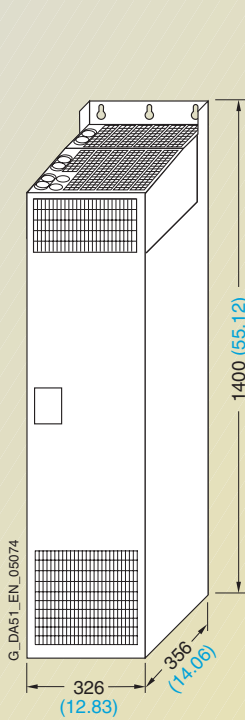

**Inverter frame size FX**



Fixing with  
 6 x M8 bolts  
 6 x M8 nuts  
 6 x M8 washers  
 Tightening torque  
 with washers  
 fitted: 13.0 Nm  
 Ventilation clearance  
 required:  
 at top: 250 mm  
 at bottom: 150 mm  
 in front: 100 mm

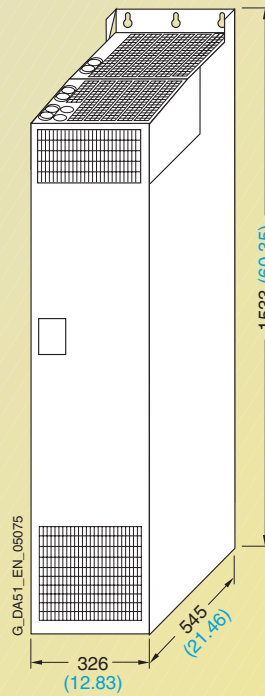

**Inverter frame size GX**



Fixing with  
 6 x M8 bolts  
 6 x M8 nuts  
 6 x M8 washers  
 Tightening torque  
 with washers  
 fitted: 13.0 Nm  
 Ventilation clearance  
 required:  
 at top: 250 mm  
 at bottom: 150 mm  
 in front: 100 mm

All dimensions in mm (values in brackets are in inches)

# MICROMASTER 430

## Dimension drawings

### EMC filter

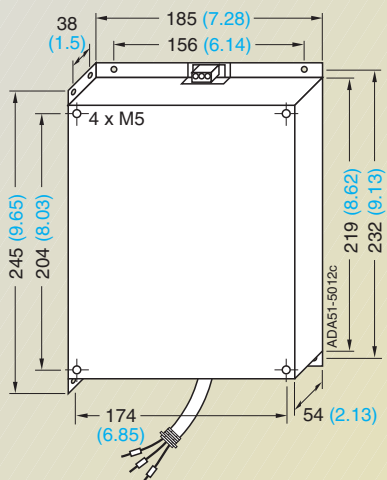

EMC filter for frame size **C**

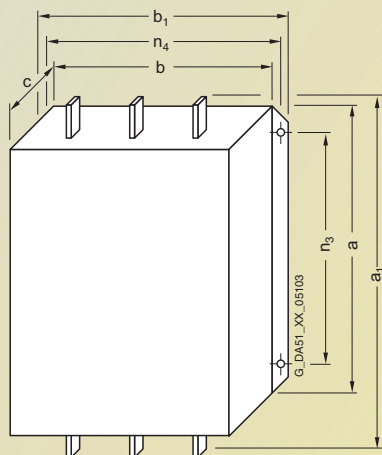

EMC filter Class A Type 6SL3000-	for inverter Frame size (FS)	Dimensions							Weight, approx. kg
		a	a <sub>1</sub>	b	b <sub>1</sub>	c	n <sub>3</sub>	n <sub>4</sub>	
0BE32-5AA0	<b>FX</b>	270 (10.63)	360 (14.17)	200 (7.87)	240 (9.45)	116 (4.57)	210 (8.27)	220 (8.66)	12.3
0BE34-4AA0	<b>FX/GX</b>	270 (10.63)	360 (14.17)	200 (7.87)	240 (9.45)	116 (4.57)	210 (8.27)	220 (8.66)	12.3
0BE36-0AA0	<b>GX</b>	310 (12.2)	400 (15.75)	215 (8.46)	265 (10.43)	140 (5.51)	250 (9.84)	240 (9.45)	19.0

EMC filter for frame sizes **FX** and **GX**

All dimensions in mm (values in brackets are in inches)

### LC filter

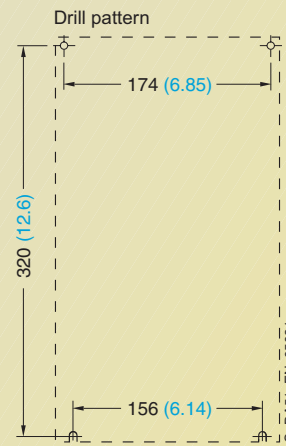
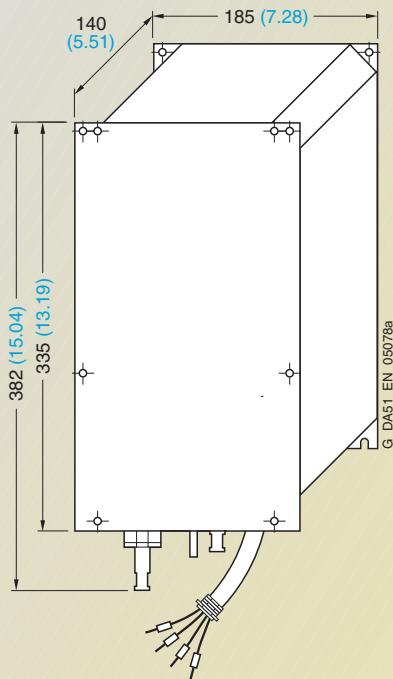

Fixing with M5 bolts

### LC filter 6SE6400-3TD03-2CD0 for frame size C

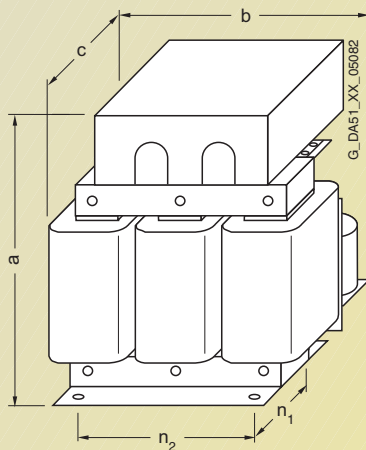

Fixing with M10 bolts

### LC filter for frame sizes D to F

LC filter Type	for inverter Frame size (FS)	Dimensions				
		a	b	c	n <sub>1</sub>	n <sub>2</sub>
6SE6400-3TD03-7DD0	<b>D</b>	278 (10.94)	240 (9.45)	230 (9.06)	115 (4.53)	190 (7.48)
6SE6400-3TD04-8DD0	<b>D</b>	290 (11.42)	240 (9.45)	240 (9.45)	125 (4.92)	190 (7.48)
6SE6400-3TD06-1DD0	<b>D</b>	345 (13.58)	300 (11.81)	220 (8.66)	120 (4.72)	240 (9.45)
6SE6400-3TD07-2ED0	<b>E</b>	355 (13.98)	300 (11.81)	235 (9.25)	145 (5.71)	240 (9.45)
6SE6400-3TD11-5FD0	<b>E/F</b>	460 (18.11)	360 (14.17)	235 (9.25)	125 (4.92)	264 (10.39)
6SE6400-3TD15-0FD0	<b>F</b>	460 (18.11)	360 (14.17)	250 (9.84)	140 (5.51)	264 (10.39)
6SE6400-3TD18-0FD0	<b>F</b>	520 (20.47)	420 (16.54)	290 (11.42)	173 (6.81)	316 (12.44)

All dimensions in mm (values in brackets are in inches)

# MICROMASTER 430

## Dimension drawings

### Line commutating chokes

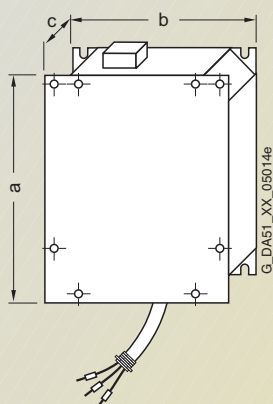

Line commutating choke for	Dimensions			Weight (max.) kg
	a	b	c	
Frame size <b>C</b>	245 (9.65)	185 (7.28)	50 (1.97)	2.3

Line commutating choke for frame size **C**

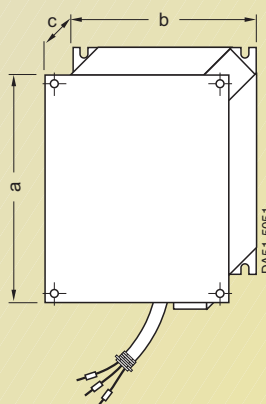

Line commutating choke for	Dimensions			Weight (max.) kg
	a	b	c	
Frame size <b>D</b>	520 (20.47)	275 (10.83)	85 (3.35)	9.5
Frame size <b>E</b>	650 (25.59)	275 (10.83)	95 (3.74)	17.0

Line commutating choke for frame sizes **D** and **E**

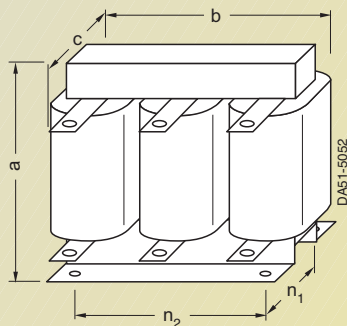

Line commutating choke for inverter frame size **F**

Line commutating choke type	for inverter Frame size	Dimensions					Weight (max.) kg
		a	b	c	n <sub>1</sub>	n <sub>2</sub>	
3CC11-....	<b>F</b>	210 (8.27)	240 (9.45)	141 (5.55)	109 (4.29)	190 (7.48)	25.0

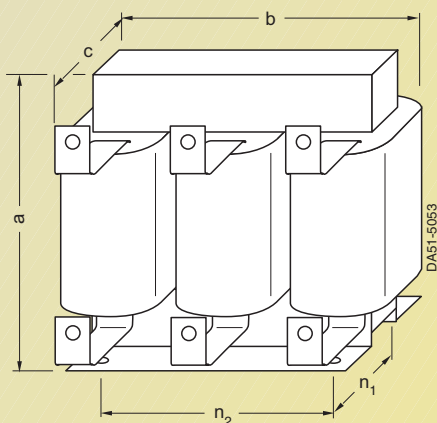

Line commutating choke for inverters of frame sizes **FX** and **GX**

Line commutating choke type	for inverter Frame size (FS)	Dimensions					Weight (max.) kg
		a	b	c	n <sub>1</sub>	n <sub>2</sub>	
0CE32-....	<b>FX</b>	248 (9.76)	255 (10.04)	203 (7.99)	101 (3.98)	200 (7.87)	24.0
0CE33-....	<b>GX</b>	248 (9.76)	255 (10.04)	203 (7.99)	101 (3.98)	200 (7.87)	25.0
0CE35-....	<b>GX</b>	269 (10.59)	275 (10.83)	210 (8.27)	118 (4.65)	224 (8.82)	35.0

All dimensions in mm (values in brackets are in inches)

### Output chokes

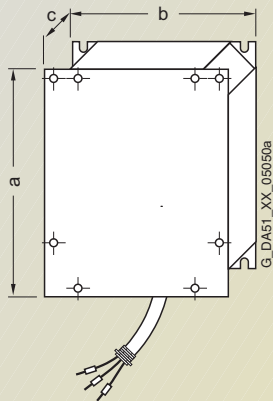

**Line commutating choke**  
for frame size **C**

Output chokes for	Dimensions			Weight (max.) kg
	a	b	c	
Frame size <b>C</b>	245 (9.65)	185 (7.28)	80 (3.15)	5.6

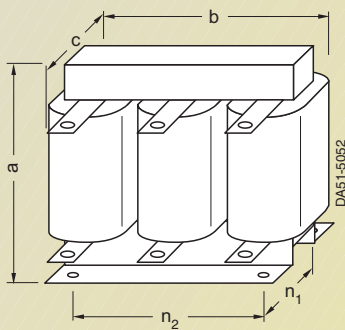

**Output chokes**  
for inverters of size **D, E** and **F**

Output choke type 6SE6400-	for inverter Frame size (FS)	Dimensions			$n_1$ $n_2$ (to DIN 41308)		Weight (max.) kg
		a	b	c			
3TC03-8DD0	<b>D</b>	210 (8.27)	225 (8.86)	179 (7.05)	76 (2.99)	176 (6.93)	16.1
3TC05-4DD0	<b>D</b>	210 (8.27)	225 (8.86)	150 (5.91)	76 (2.99)	176 (6.93)	10.7
3TC07-5ED0	<b>E</b>	248 (9.76)	270 (10.63)	209 (8.23)	88 (3.46)	200 (7.87)	24.9
3TC08-0ED0	<b>E</b>	210 (8.27)	225 (8.86)	150 (5.91)	76 (2.99)	176 (6.93)	10.4
3TC14-5FD0	<b>F</b>	321 (12.64)	350 (13.78)	288 (11.34)	120 (4.72)	264 (10.39)	51.5
3TC15-4FD0	<b>F</b>	210 (8.27)	225 (8.86)	150 (5.91)	76 (2.99)	176 (6.93)	11.2

All dimensions in mm (values in brackets are in inches)

## Dimension drawings

### Assembly of inverter and options

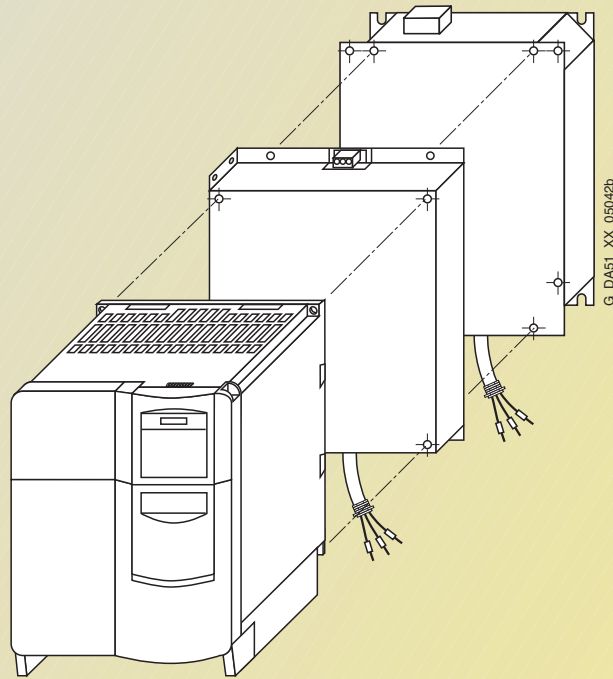

Example:  
Assembly of  
inverter, filter and choke  
If additional options are  
required, they must be  
mounted on the side.